

# Junk Rig for Beginners

by Arne Kverneland

(Ver. 20141029)

*The following is an explanation of the basics of the junk rig (JR). It is aimed for sailors with some experience with other rigs; Bermudian, Gaff, Sprit or Lug, but who are new to this one.*



**Johanna**, 29ft, 48sqm sail



**Samson**, 49ft, 70 + 37 sqm sails



**Malena**, 23ft, 32sqm sail

## Why junk rig?

Before giving details let me explain why I converted my boat, *Malena*, from Bermudian to JR, back in 1990.

- ***I wanted to sail downwind with better speed and less fuss.*** This was actually the main reason for converting my first boat. The masthead Bermudian (Bm) rig is such a pain to sail downwind, requiring careful helming and lots of deck-work to boom out the genoa or spinnaker which is not fun for a single-hander. The JR did not disappoint me here: With the single big sail squared out, unrestricted by shrouds, the downwind leg suddenly gave really easy sailing, and the speed went up a lot...
- ***I wanted a self-tacking rig.*** I surely got that. The genoa winches were soon removed.
- ***I wanted to get rid of all the sail bags taking up space down below.*** Oh yes, three foresails and a spinnaker...
- ***I'd heard about the JR's fast reefing and furling.*** That really works too. Now I hardly go on deck after leaving the harbour.
- ***The blind zone of the genoa had given me a few real scares.*** A double Oh Yes! With the JR there is suddenly a free view all around.
- ***New literature available.*** Yes, on a sailing trip to the Shetland Isles in 1989 I was able to buy the new book; *Practical Junk Rig* by Hasler & McLeod. With that in hand I was able to set to work.

## Performance in practice

If you fit your boat with a well-made junk rig with cambered panel sail(s), you can expect to just about keep pace with a Bermudian rigged sister boat when close-hauled. As both boats fall off onto a reach, your JR boat will soon take the lead, and on a straight downwind leg, the JR will be in a different league. A spinnaker set on the Bm rigged boat may change this, but only if the crew is good. On all but on the close-hauled leg the JR boats seem to sail more upright than the Bm rigged boats. Easing the sheet of the JR gives better airflow than when easing the sheet on a genoa.

With a JR boat your sailing style will change. Soon after experiencing the easy reefing, you will hang on to full sail for longer: Reefing will be done to suit actual wind strength and not to

the wind strength forecasted on the radio. Narrow sounds with headwinds will no longer be a start-the-engine situation – you will just tack your way through it. Pinching the boat to round a point will also be out as an extra tack or two is no problem, so you will just sail the boat for best progress. When sailing with novice crew on board, they will generally relax quite quickly as there are no genoa sheets to handle when tacking and as there is no noise from the JR as the boat comes about.

### **What is a junk rig, technically speaking?**

The JR is basically a fully battened, balanced lug sail, in other words a self-tacking fore and aft sail. The main difference is in the battens which are not bendy, and therefore are more like intermediate booms or yards. In addition, the sheet is not only attached to the boom, but also to most of the battens. This may sound like an insignificant difference, but when it comes to distribution of stress and to sail handling, the difference is huge. More about that later.

### **Sail plan, the profile of the junk sail**

For simplicity I have only drawn a sloop (single sail) JR here, but JR can also be rigged on ketches, yawls and 2-3 masted schooners as well.

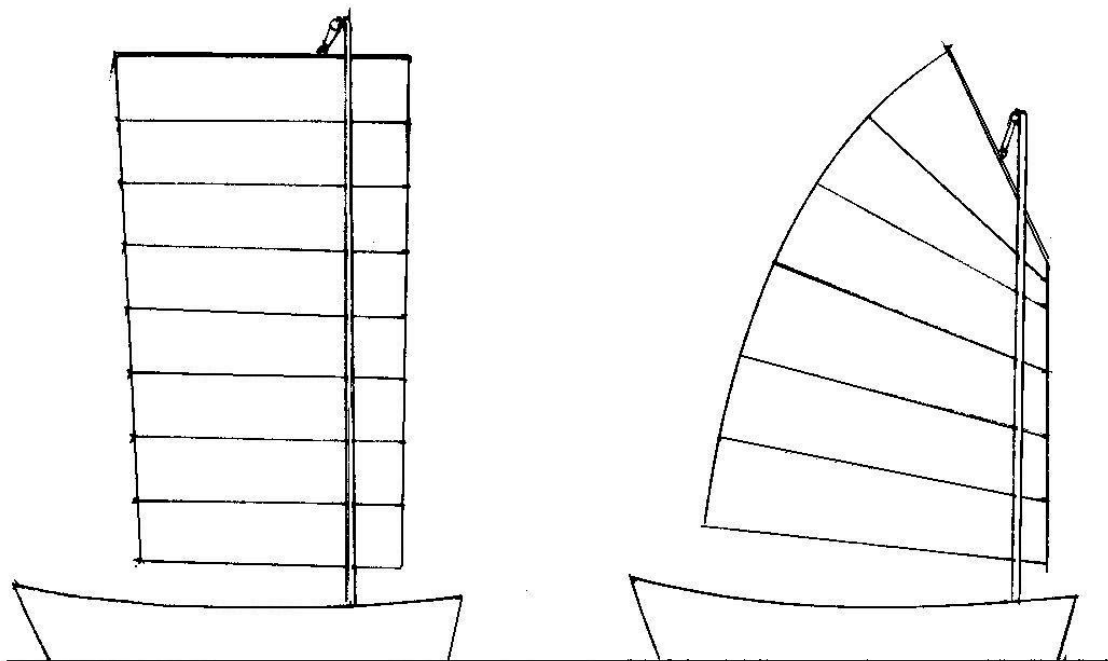

**Fig 1.**

There are scores of different sail profiles to be found of the original Chinese junk rigs, yet it seems that two shapes predominate. These are the sails with parallel battens (Fig 1, left) and some variant of the fan-shaped sail (Fig 1, right). The number of panels varies from 5 to over 20. The strength of the sail material has an influence on the number of panels. The early woven bamboo fibre matting was rather weak and requires many battens to support the panels, while the much stronger cotton duck can use much fewer battens. This cotton canvas became available very late; in the 19<sup>th</sup> century in China, and my guess is that this led to some re-designing of the rigs.

*The western interpretations of the Chinese JR* is without exception the low-number-of-panels type, since strong canvas is easy to find. I have seen sails with anything from 4 to 9 panels, but 6 to 8 seem to be by far the most common.

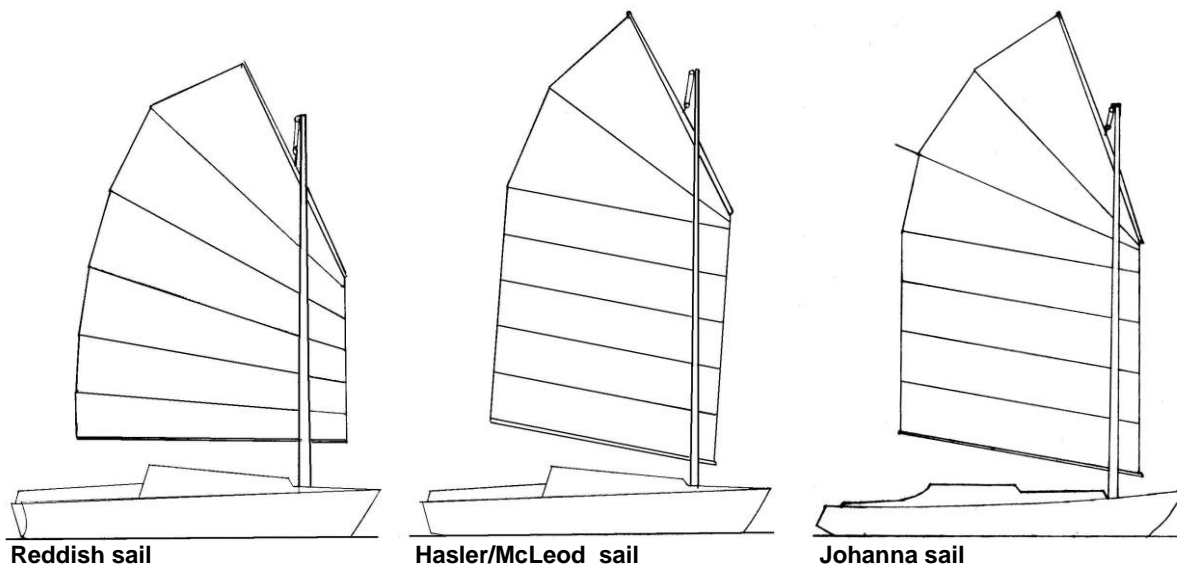

**Fig 2.**

The fan-shaped sail to the left on Fig 2 is a copy of the one Vincent Reddish made after having analysed a number of Chinese rigs.

In the seventies H.G. Hasler and Jock McLeod teamed up to develop the western junk rig. They came up with a mix of the parallel-battened and fan-battened sail (Fig 2 middle). This was the shape I used for my first sail on my *Malena* in 1990. You can read more about their sails and every aspect of the JR in their monumental work, *Practical Junk Rig*.

Fig 2, right shows the sail I rigged on my present boat, *Johanna*, in 2002. It is essentially a Hasler/McLeod rig, but with 3 exceptions:

1. The yard has been raised to about 70° to make it easier to let the sail sit vertically. With a vertical leech there is less chance for the sheets to get caught by the battens or the boom when tacking or gybing (more later on this).
2. Panel no 3 from top I built as a *transitional panel*. It helps to keep the top un-sheeted panels from being too big with the high-peaking yard. I adjust this panel so that all panels end up with approximately equal area (give or take up to 5%).
3. I make the sail with camber (bagginess) sewn into each panel. More about that later.

(.. I now have more or less settled on this basic Johanna-style sail profile, but of course different boats need sails with different aspect-ratios, so I adjust this to suit the needs..)

### **Standing rigging**

There's not much to say about it – the JR masts are normally not stayed. Without staysails there is no compression load to speak of, so there is no real need for staying. This gives the additional benefit of allowing the sail to be squared off on the downwind leg. It also means that there should be no accidental gybes.

### **Running rigging**

*The halyard* is very straightforward and needs no explaining figures apart for Fig 1 and 2. There is one halyard fixed to the yard close to the mid-point. A small sail will do with a simple one-part halyard. As the sail grows in size, 2-, 3-, and up to 5-part purchase is used. I

recommend using good blocks with ball bearings for the halyards. This makes hoisting easier and the sail also comes down faster.

.. *Sheets..*

As the sheeting systems are more complicated, I will only mention the basics here. The whole idea is to spread the sheet forces over the battens so that the sail will set with about the right twist in it. To achieve this, the sheet is connected to the battens via sheetlets (also called sheet spans).

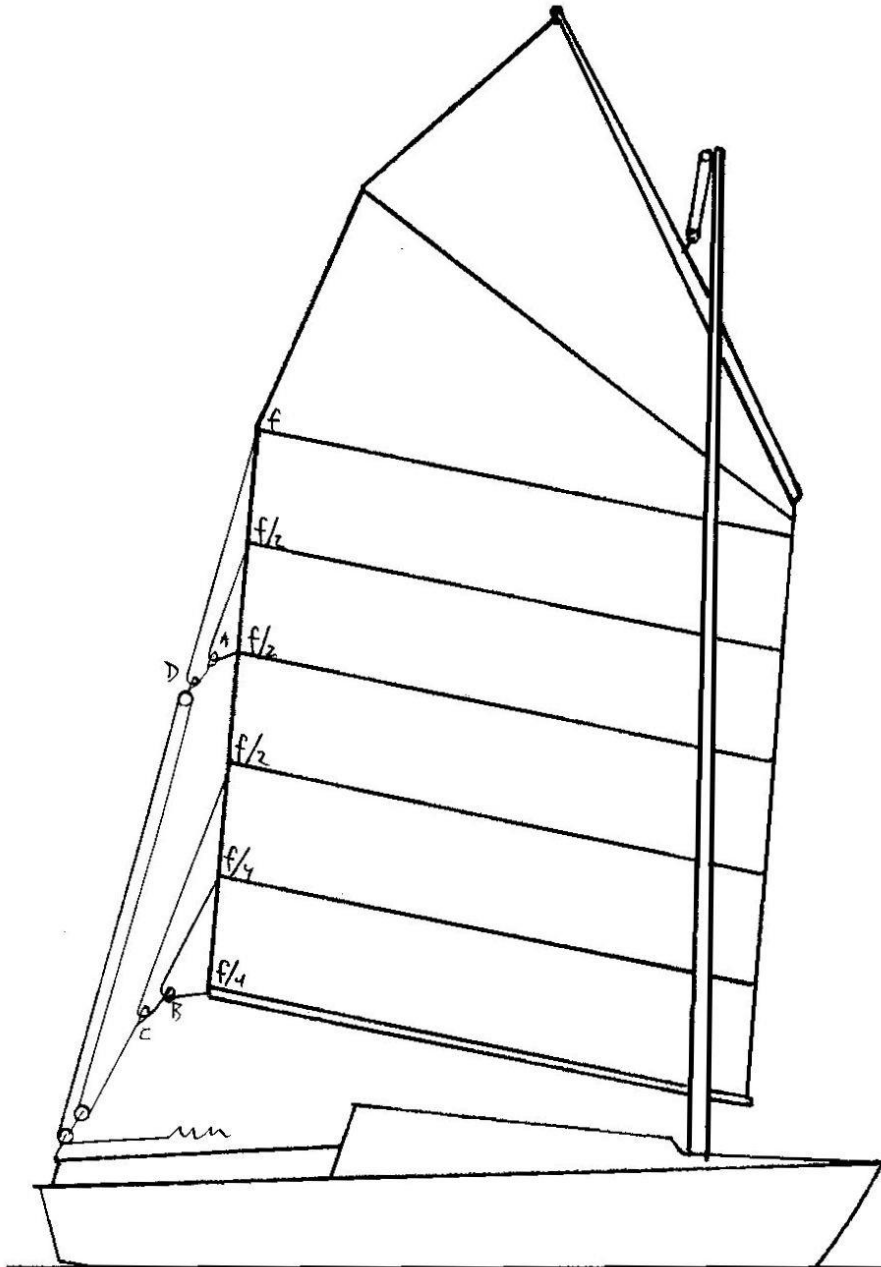

**Fig 3. The Pilmer sheeting**

The sheeting shown in Fig 3 is named after Hasler's boat, *Pilmer*. I used this system on my first flat junk sail on *Malena*. It was simple and worked well and didn't take up too much space between the clew and the sheet-point on the boat though the sail twist was just a bit on the high side. Note the distribution of sheet forces on the battens.

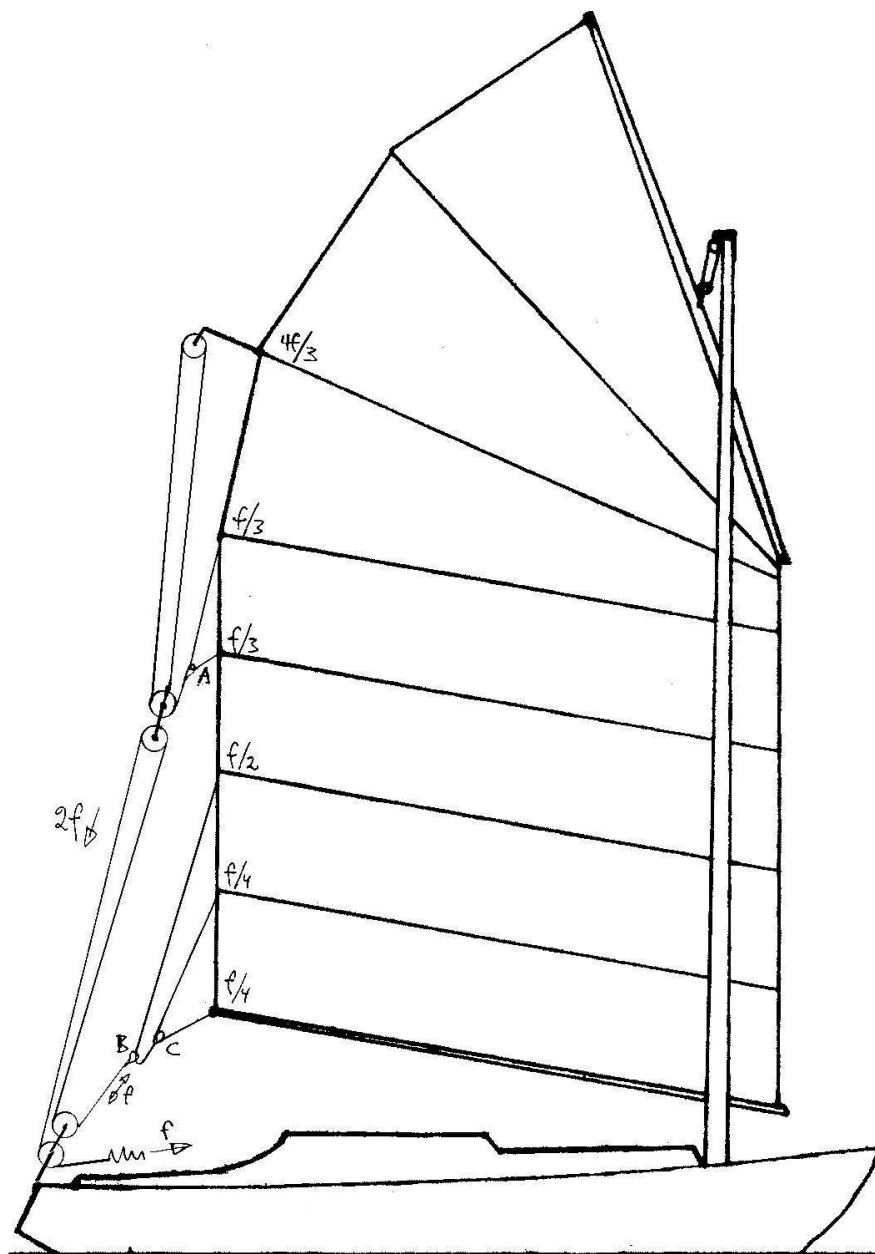

**Fig 4. The Johanna-sheeting**

Fig 4 shows the sheeting I use on *Johanna* today.

This setup has a stronger anti-twist function. The upper sheetlet takes up more space than the Pilmer version, but it is worth fitting it.

If a sail turns out to have too much twist in it and there is no room for the Johanna-sheeting, then it is possible to split the sheet into upper and lower parts. This gives you two hauling ends, but that is no real problem. The bonus is that you can have better control of the twist as the sail is being reefed.

### ..Lazy Jacks...

Most sailors have seen some sort of *lazy jacks* (also called *buntlines*) in use on gaffers and Bm-rigged boats. Little do they know that these “modern gadgets” have been in use in China for well over 2000 years. Unlike the western rigs where the lazy j. are nice to have, on the Chinese JR they are absolutely essential, as the JR reefs by lowering the sails into the lazy jacks. This means that the lazy jacks must be made from stout chafe-resistant rope and be checked, maintained and replaced with the same regularity as the halyard.

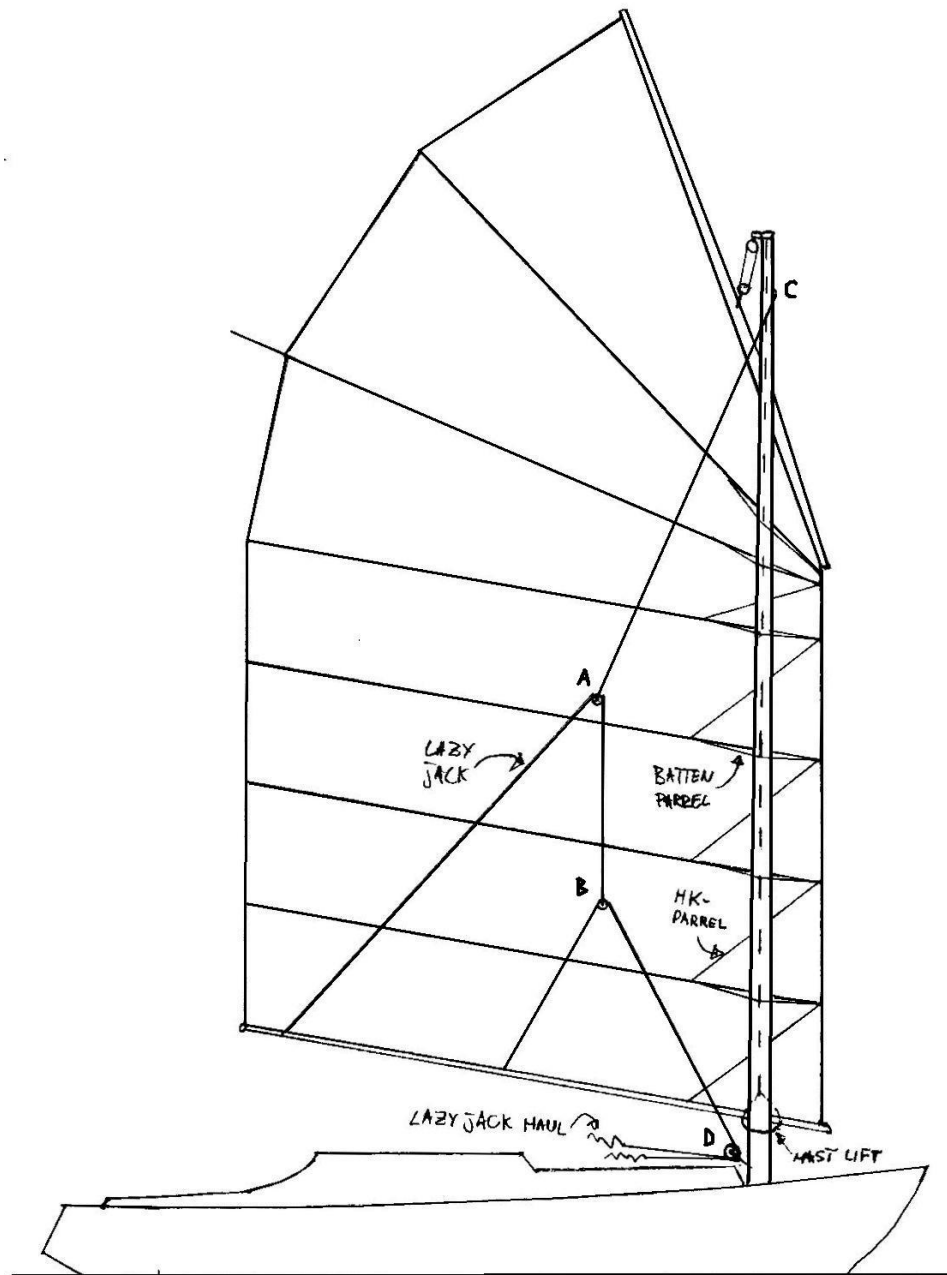

**Fig 5. Lazy jacks, mast lift, batten parrels and Hong Kong parrels**

The lazy jacks, coming down on both sides of the sail collect the sail bundle as the sail is lowered. If the lazy j. are of the running version as on Fig 5, they double up as adjustable topping lifts. The port and starboard top section (A – C) is suspended from the mast top and laced together at C where they split and lead down to next section at point A. If the lazy j. are to be running, blocks are fitted in A and B. On my boats I’ve only used standing lazy j. so I

only use spliced loops in A and B. I get away with it by using 10mm hard-spun 3-strand rope. It probably would make sense to splice in plastic thimbles.

**..mast lift...**

To hold the boom up in the fore end, there is a so-called *mast lift*, also shown on Fig 5. This also has a lazy j. function as the sail is coming down.

**..batten parrels...**

The *batten parrels* (Fig 5) hold the battens loosely to mast. They may be made short to hold the sail in a fixed fore - aft position, or they may be made long to enable the skipper to adjust the position of the sail under way. The drawn version is somewhere in between,

**..Hong Kong parrels (Fig5)...**

The *Hong Kong parrels*' job is to support the panels diagonally. Without them some big diagonal creases tend to show up, particularly on cambered panel sails where there is little diagonal rigidity in each panel. These parrels were spotted on junks in the Hong Kong area using fanned batten sails with 6-7 panels. On my cambered panel sails they are essential and they also make the setting up of the *luff hauling parrel* and *yard hauling parrel* much easier. The HK parrels need no attention after the initial setting up. Note that the HK parrels must pass on the sail side of the mast to keep equal tension on both tacks.

**..controlling the fore-and-aft position of the sail...**

See Fig 6, overleaf.

The line which hauls the yard forward is called the *yard hauling parrel*. This line has little use when the sail is fully hoisted. However, when the wind picks up and panels have to be lowered, the yard h.p. together with the *luff hauling parrel* (Fig 6) are needed to fix the sail's position and stopping the yard from sliding back and forth as the boat pitches.

From the block on the yard the hauling end of the yard h.p. is passed down inside the lazy jacks but outside the batten parrels. The *luff hauling parrel* can take many different arrangements. Normally it is a running line, but can also be made as a standing version.

On my Johanna I have fiddled with many versions of luff hauling parrel, some more complicated than the others. Finally I understood that its main job was to pull the throat end of the yard down and aft to counterbalance the sheet forces. I have dropped the block at C (Fig 6) so that now the hauling line is passed down to the deck block at D directly from the block at B, inside the batten parrels, but outside the HK parrels. I think the HK-parrels help to keep the luff straight without needing a more complicated system of parrels.



On this photo (p.7) Johanna has dropped a panel. With no downhauls and only that simple A-B luff hauling parrel, the luff still stands quite straight apart from in the lowest panel.

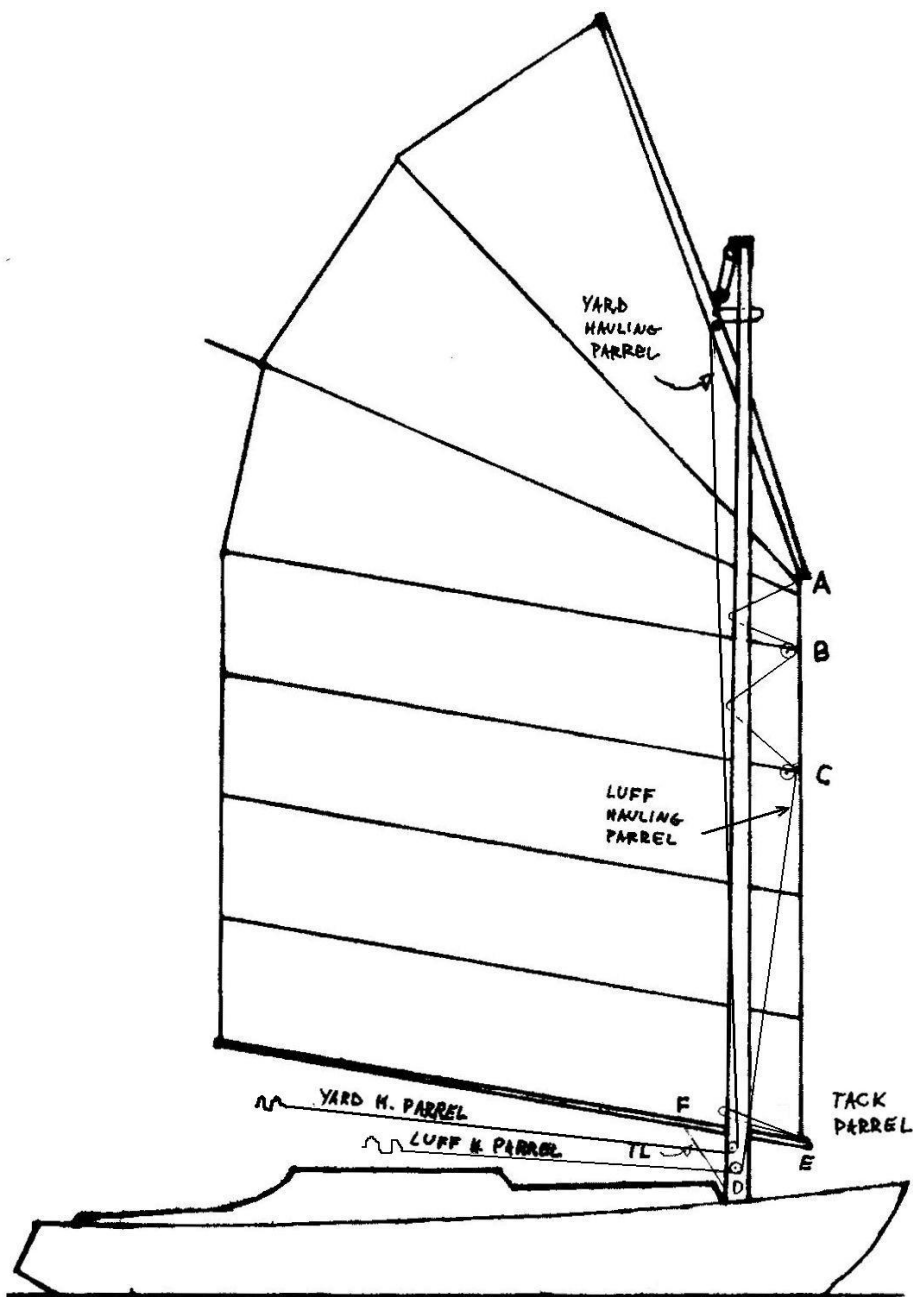

Fig 6. Yard h. parrel, luff h. parrel, standing tack parrel, standing tack line

On Fig 6 the tack is being held aft by a simple hoop of webbing, called the (standing) *tack parrel*. This is being passed inside everything and above the mast lift. There is also a *tack line*, attached to the boom at F. Since the boom is not prone to swing aft of its shown position, point F can be closer to the mast than shown. I use a rubber shock-chord on the tack line since with fully hoisted sail it would otherwise become terribly taut with the sail fully squared out.

Although I have not explained the long batten parrel version with fully adjustable for-aft position of the tack, it may be needed if you have a broad sloop rig and you discover that you run out of rudder control on a broad reach...



### *..summing up the strings..*

All the strings shown in Fig 4, 5 and 6 sum up to a considerable number. Still, on my boats only 4 of them are running; *Sheet, Halyard, Luff Hauling Parrel and Yard Hauling Parrel*. That's all.

### **Sailing with the JR**

Handling a junk-rigged boat is easy.

#### *..hoisting sail..*

My sloop-rigged boats live in floating berths. On *Johanna* I remove the sail ties and halyard tie (to keep it from tapping against the mast) before I motor out into the narrow bay where I stop the boat on starboard tack. This lets me see the parrels etc, but also puts the boat in the right-of-way position. With the boat stopped I lock the tiller to leeward and then I cast off the sheet, the luff h.p. and yard h.p. before hauling on the halyard. On *Johanna's* 48sqm sail I hoist 5 panels by hand in one go, keeping an eye on the sheet to see that it runs out smoothly. Then I take a little break while stuffing the halyard in a bag. Back to hoisting, I crank up the last 2 panels with the winch and stuff the rest of the halyard in the bag. A quick setting up of the two running luff- and yard parrels before going back to stop the outboard engine and swinging it up out of the water. Now finally, after some 5 (or 10?) minutes we are ready to go. During all this time, *Johanna* has moved very little, maybe 5 or 10 boatlengths as she is actually caught in irons. Then I just haul in on the sheet, grab the tiller and we are on our way. **Tacking** is as mentioned before, just a matter of putting over the tiller. So easy. **Gybing** can either be made as a short gybe – you haul in on the sheet, gybe, and then pay out sheet again. The long gybe really is long: With the sail fully squared out you round up fast until the sail gybes – you will be almost on a beam reach before it happens. The sail flies over, but will actually be stopped by the wind on the other side with no jerk in the sheet. I've done this in winds up to Force 6. Such gybes demand that you have a tidy cockpit where the sheets cannot catch anything. Sometimes I would rather tack the boat around instead of gybing...

I usually stop the boat before **reefing the sail** when I'm alone. I just ease the sheet and let the tiller go, and the boat continues slowly. Then I lower as many panels as I want and readjust the parrels (luff and yard) which will have gone slack. Then we are off again. As halyard and parrels are lead aft, there is no need to leave the cockpit after casting off.

**Heaving too** in sheltered waters is actually the position I put the boat in when hoisting sail; sheet fully out and the tiller fully to the lee. Like this she will lie for as long as you like. It is not so simple offshore. With a sloop I think it is better to drop sail to 1 or 2 panels and then set the wind vane to pinch the boat closely into the wind and thus just creep forward. Before **furling the sail** I usually lower the outboard engine and start it. Then I head the boat up as for tacking, hauling in on the sheet. As we pass head to wind, I cast off the halyard and down comes the sail in 3-4 seconds. With the sheet already shortened in, there will not be much of it in the water, so the rest is quickly hauled in. Then I secure the sail bundle and we head for the harbour. In practice I tend to *sail* the boat back into berth half the time as the winds are generally favourable.

### **A little note on camber in junk sails**

The first westernised junk rigs had flat sails and most of today's junk sails are still flat. This has rightly given the rig a reputation of being bad for upwind work. In practice a boat fitted with a JR with flat sail will point 5-10° lower than a Bm-rigged sister boat. The difference is worst in light winds where progress to windward can be painfully slow.

I will not go in details on aerodynamics, but for the last 100 years it has been known that to get most out of a sail or wing, one must have a steady airflow on both sides. With a flat sail

one can only achieve this flow with the angle of incidence being very low and then the sail or wing will hardly produce any lift.

Like any other sail a Chinese junk sail needs camber to work well. As I see it there are 5 ways of achieving camber which either have been used by the Chinese, by the West or by both.

- **Bagginess in the panels due do stretchy sail cloth.** This can be seen on many Chinese JRs. When westerners took to JR they skipped this element as it looked so untidy...
- **Adjustable camber by adjusting the twist in the fanned batten sails.** This was also much used by the Chinese sailors. In Britain Vincent Reddish has described the method and it works for him though I haven't tried it myself.
- **Bendy battens.** The Chinese didn't use the method systematically, but you can't keep the battens 100% straight under load, so most battens add 1-3% camber anyway. In the west it has been tried using GRP tubes which should bend to a desired camber. The problem is that in light wind when you need camber, the battens are straight. In strong wind when you need a flattish sail, the battens bend too much. Everyone seems to drop this method after a while.
- **Hinged battens** have been tried with more success. This gives a constant camber, independent of wind strength. I used it from 1991 to 1994, on and off. Some are being manufactured in plastic in Britain, but these seem to break too often.
- **The cambered panel junk sail** was my way of emulating the original Chinese baggy panel method even with the sailcloth being a lot stronger than the cotton cloth the Chinese used. I have used the method since 1994 and it works well. Pointing angle is within 5° of an equivalent Bermudian rigged boat. All the sails pictured in this little article are of this type.

### Finally

Now that the problem with upwind performance has been sorted out, I'm not afraid of recommending the JR to anyone. Some of my friends already sail with these rigs – and they still speak to me...

Stavanger, 20091106

*Arne Kverneland*

(e-mail a-kve2@online .no)



..18ft dinghy Broremann with 10sqm sail. Note the mast lift and simple lazy jacks...

PS: It doesn't take a ship to have fun with a JR. My 18ft *Broremann* has surprised me this summer...

PPS: **Thanks a lot to Slieve McGalliard for proof-reading this text for me.**

PS, 20141029: More about designing and making a JR can be found here: <http://www.junkrigassociation.org/arne>